

# BENNE TRAPEZIE ORIENTABILI

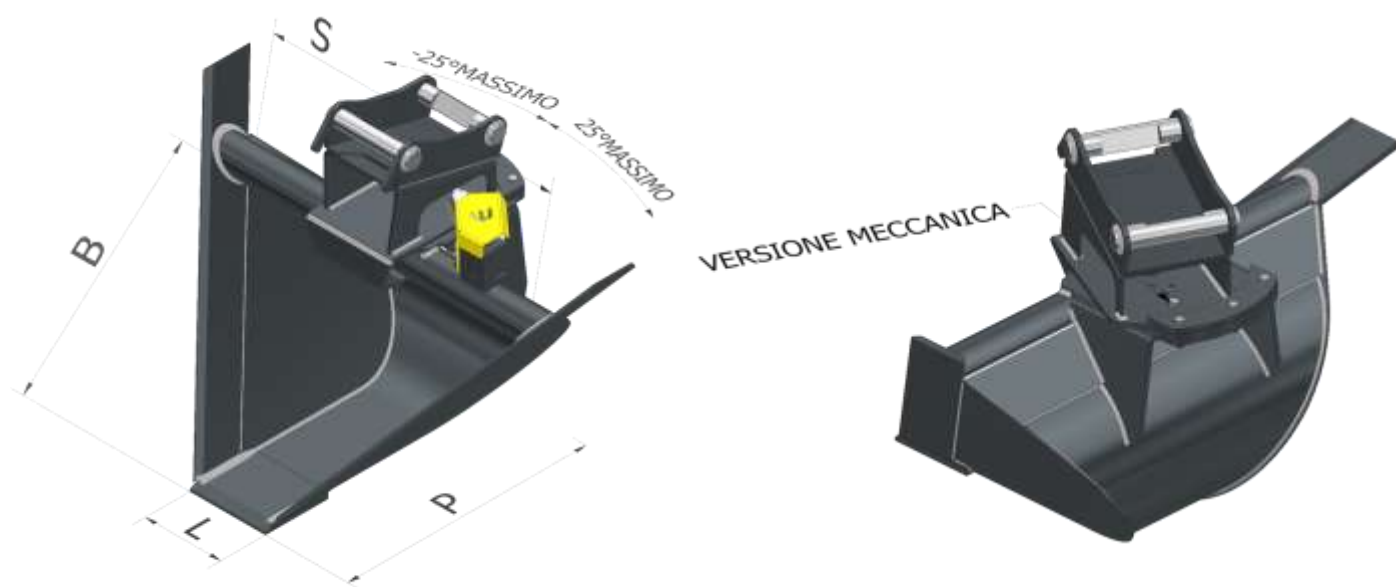

## TRAPEZIE ORIENTABILI 60°

MOD	TON	L	B	P	S	PESO*	CAP. SAE	STD-AR CR	KLAC
TO44	1,8-2,8	250	450	535	632	51 kg	55 l	AR30 CR30	D
TO50	2,8-3,5	250	520	600	715	90 kg	78 l	AR40 CR40	D/E
TO55	3,5-5,0	300	595	710	820	106 kg	116 l	AR50 CR50	E
TO65	5,0-7,5	300	690	825	910	152 kg	168 l	AR50 170 CR50 170	f
TO75	7,5-10,0	300	820	950	1030	232 kg	243 l	AR70 CR70	f

## TRAPEZIE ORIENTABILI 52°

MOD	TON	L	B	P	S	PESO*	CAP. SAE	STD-AR CR	KLAC
TO44	1,8-2,8	250	450	535	775	56 kg	60 l	AR30 CR30	D
TO50	2,8-3,5	300	520	600	940	97 kg	100 l	AR40 CR40	d/e
TO55	3,5-5,0	300	595	710	1010	119 kg	136 l	AR50 CR50	E
TO65	5,0-7,5	300	690	825	1135	171 kg	200 l	AR50 170 CR50 170	f
TO75	7,5-10,0	300	820	950	1300	282 kg	295 l	AR70 CR70	f